

Latest Version: 8.0

Question: 1

What is a function of the metadata service in an object-based storage device (OSD)?

Response:

- A. Generates the file system namespace from the file contents.
- B. Manages both physical and logical disks on which the user data is stored.
- C. Manages the storage space for all remote clients.
- D. Maintains the object IDs and file system namespace mappings.

Answer: D

Question: 2

Which action takes place during the login phase in an FCoE SAN?

Response:

- A. VN_Ports obtain FC addresses
- B. Nodes locate the Fibre Channel Forwarder
- C. Initialization protocol starts transporting FC data
- D. VN_Port to N_Port pairing is established

Answer: A

Question: 3

Which cloud computing characteristic enables consumers to use cloud services on heterogeneous thin or thick client platforms?

Response:

- A. Resource pooling
- B. High availability
- C. On-demand self-service
- D. Broad network access

Answer: D

Question: 4

Which cloud computing characteristic enables multi-tenancy and abstracts the location of provided resources?

Response:

- A. Resource pooling
- B. Measured service
- C. Rapid elasticity
- D. Broad network access

Answer: A

Question: 5

Which client-server protocol uses a ticket-based authentication mechanism?

Response:

- A. CHAP
- B. Kerberos
- C. iSNS
- D. OpenID

Answer: B

Question: 6

What is an accurate statement about hypervisor-based continuous data protection (CDP)?

Response:

- A. Write splitter is embedded in the hypervisor
- B. Journal is stored in a virtual machine
- C. Journal and replica use the same storage volume
- D. Virtual appliance runs on a storage system

Answer: A

Question: 7

Why is it important for organizations to implement a multi-site remote replication solution?

Response:

- A. Ensure data protection is always available if there are any single site failures
- B. Provide consistent near-zero RPO in the event of source and remote site failures
- C. Perform synchronous replication with low network bandwidth
- D. Recover data to any point-in-time in the event of a remote site failure

Answer: B

Question: 8

If a company has experienced a passive attack on its IT infrastructure, how is the company's security impacted?

Response:

- A. Access to services is denied.
- B. Availability of data is affected.
- C. Information privacy is compromised.
- D. Data is altered by an unauthorized user.

Answer: C

Question: 9

Which Fibre Channel (FC) interconnectivity option is represented in the graphic?

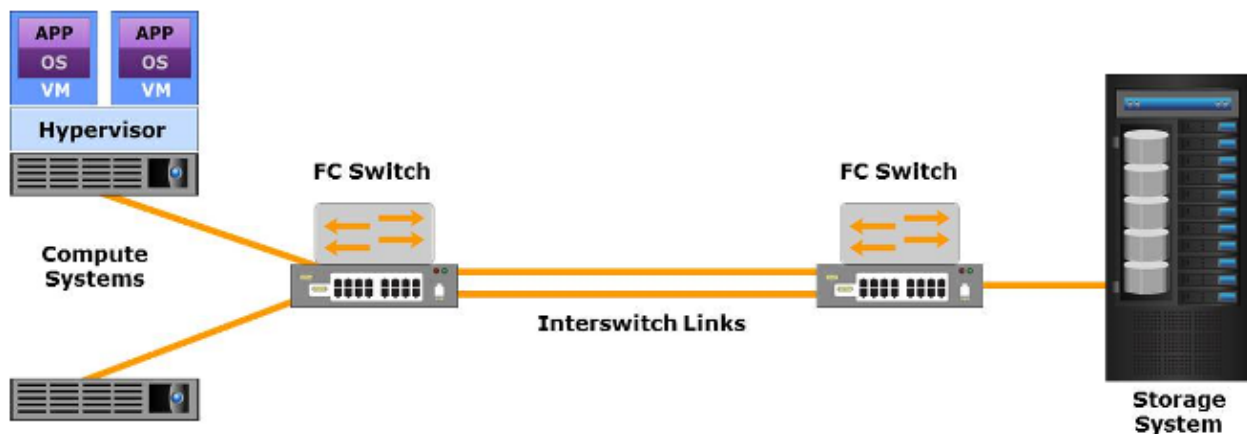

Response:

- A. FC-AL
- B. FCoE
- C. FC-SW
- D. Point-to-Point

Answer: C

Question: 10

What does the "X" represent in the exhibit?

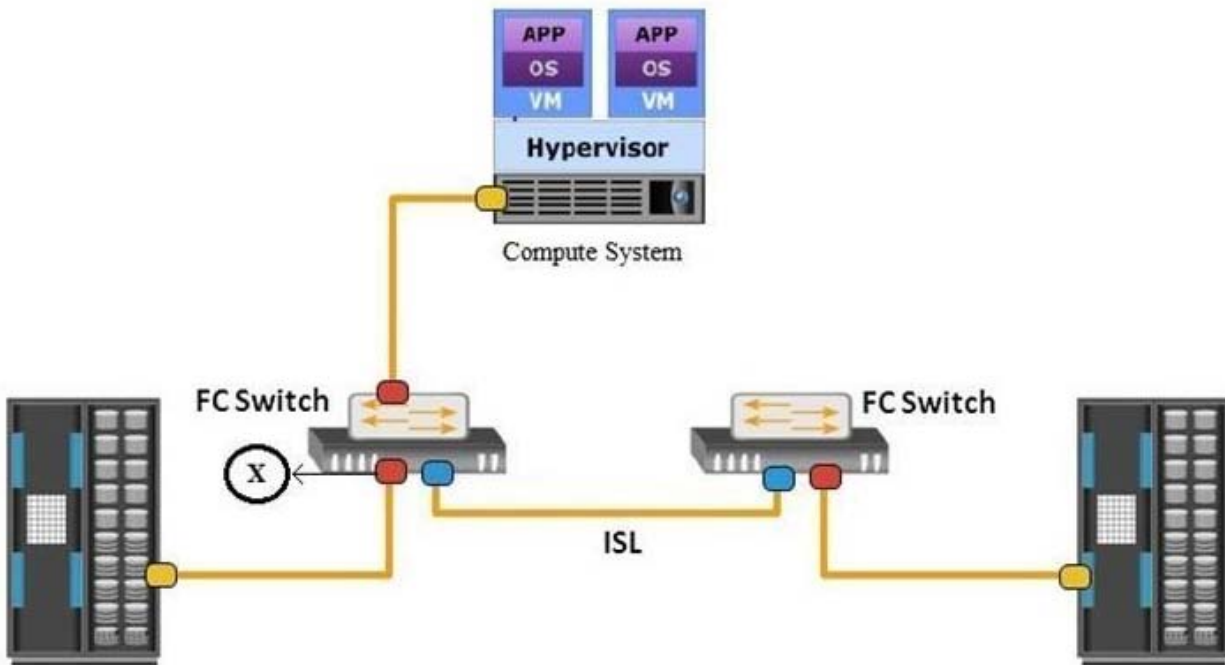

Response:

- A. E_port
- B. F_port
- C. N_port
- D. NL_port

Answer: B

Question: 11

Why do organizations prefer to adopt Disaster Recovery as a Service (DRaaS)?

Response:

- A. Increase the effective utilization of hardware resources in their data centers
- B. Eliminate both CAPEX and OPEX in managing disaster recovery at remote sites
- C. Understand and learn DRaaS best practices from service providers
- D. Avoid maintaining a complete set of IT resources in a remote data center for disaster recovery

Answer: D

Question: 12

What is the correct sequence of steps to authenticate an initiator and a target using one-way Challenge Handshake Authentication Protocol (CHAP) after the initiator performs a login to the target?

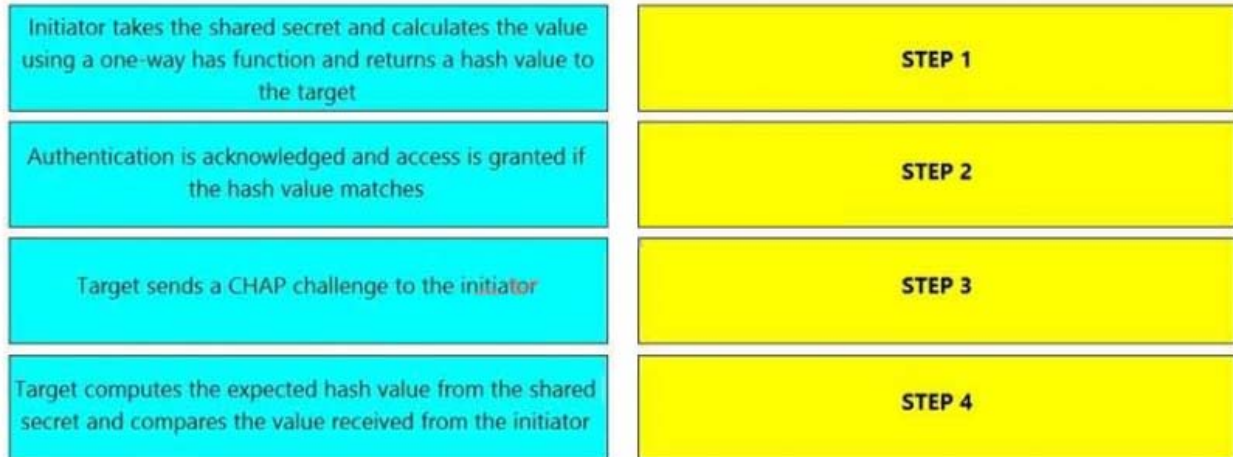

Solution:

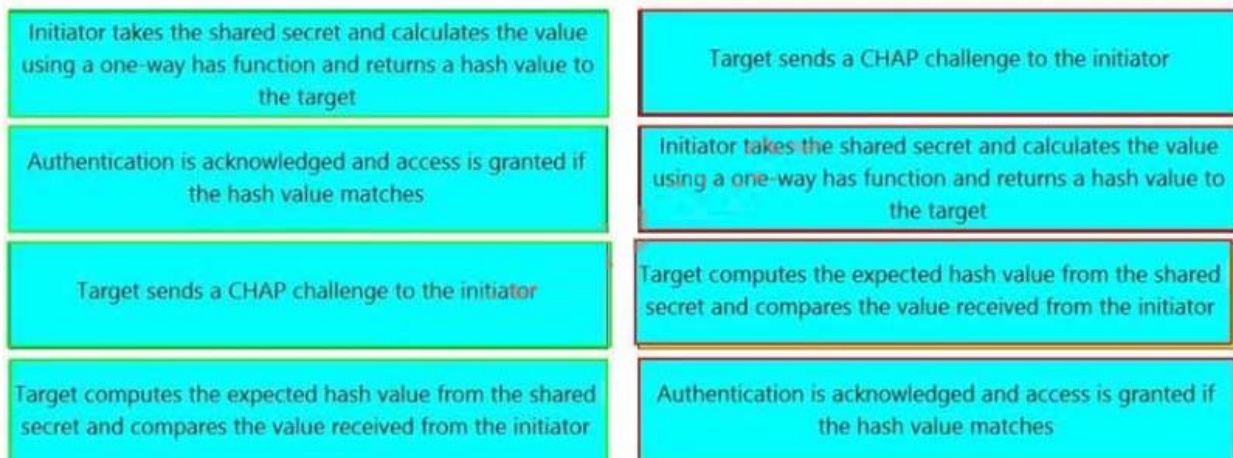

Determine whether the given solution is correct?

Response:

- A. Correct
- B. Incorrect

Answer: A

Question: 13

What keeps the name server up-to-date on all switches in a fabric?

Response:

- A. SW-RSCN
- B. Management server
- C. Zoning
- D. FLOGI

Answer: A

Question: 14

Which component initiates scheduled backups during backup operations?

Response:

- A. Backup server
- B. Backup client
- C. Backup storage node
- D. Backup device

Answer: A

Question: 15

In a virtualized environment, which method enables a virtual machine to be rolled back in case of a logical corruption to the virtual machine?

Response:

- A. Virtual volume replication
- B. VM snapshot
- C. Storage array volume replication
- D. VM clone

Answer: B

Question: 16

What is an accurate statement about image-based backup of virtual machines (VMs)?

Response:

- A. Backup agents run only inside the VM
- B. Backup processing is offloaded from the hypervisor
- C. Backup process does not use snapshot technology
- D. Backup agents run on both the VMs and hypervisor

Answer: B

Question: 17

What is determined by the amount of space configured for the journal in continuous data protection (CDP) replication?

Response:

- A. Length of time required to recover the data
- B. Length of time the recovery points can go back
- C. Amount of data that can be restored to a specific point
- D. Amount of space the source and replica volumes require

Answer: B

Question: 18

What is a component of an FCoE switch?

Response:

- A. Ethernet Bridge
- B. Virtual N_Port
- C. Converged Network Adapter
- D. FCIP Forwarder

Answer: A

Question: 19

Which EMC product is a VNX array-based local replication software that creates a full volume mirror of the source?

Response:

- A. SnapView Snapshot
- B. SnapView Clone

- C. TimeFinder/Snap
- D. TimeFinder/Clone

Answer: B

Question: 20

What does an area ID represent in Fibre Channel (FC) addressing?
Response:

- A. Group of switch ports
- B. Switch within a group
- C. Port within a group
- D. Group of switches

Answer: A